

Standard AC Motors

# Brake Pack

Introduction

Induction Motors

Reversible Motors

Electromagnetic Brake Motors

V Series

Clutch & Brake Motors

Synchronous Motors

Low-Speed Synchronous Motors

Waterright Dust-Resistant Motors

Torque Motors

Right-Angle Gearheads

Linear Heads

**Brake Pack**

Brake Pack

Accessories

Installation

# Brake Pack SB50W

● Additional Information ●  
 Technical reference → Page G-1  
 Safety standards → Page H-2

The **SB50W** provides instantaneous stop, bi-directional operation and electromagnetic brake control functions integrated into one unit. This brake pack can sense when the thermal protector is opened, further ensuring the safety of your equipment. For greater convenience, a function has been added to reset alarms using an external signal.



● For detailed product safety standard information including standards, file number and certification body, please visit [www.orientalmotor.com](http://www.orientalmotor.com).



## Features

### ● Four Functions in One Integrated Unit

The **SB50W** provides instantaneous stop, bi-directional operation, electromagnetic brake control and thermal protector open detection functions\*.

\*Thermal protector open detection function

(Available only when combined with a motor having a built-in thermal protector)

When the motor's thermal protector (overheat protection device) is activated, the **SB50W** outputs an alarm signal and automatically cuts the power supply to the motor. The motor will not restart by itself, even after the temperature drops and the thermal protector closes.

The alarm can be reset with external signals.

### ● Wide Voltage Range of 100 to 230 VAC

The **SB50W** covers a single-phase voltage range of 100 to 230 VAC  $\pm 10\%$ , accommodating major voltages used throughout the world. Use this product according to the power supply voltage of applicable motors.

### ● Conforms to Safety Standards

The **SB50W** is recognized by UL and CSA, and the CE Marking is used in accordance with the EMC Directive and Low Voltage Directive.

### ● Supports Motors with 1 W to 90 W (1/750 HP to 1/8 HP) Output

The **SB50W** can be used with induction motors, reversible motors, electromagnetic brake motors and watertight, dust-resistant motors with an output power of 1 W to 90 W (1/750 HP to 1/8 HP).

### ● Switchable Sink/Source Logic

Select sink logic or source logic for the input/output circuit. You can change the setting at any time.

### ● Instantaneous Stop

The electronic brake stops the motor instantaneously. A large braking force causes the motor to stop in approximately 0.1 second, allowing for an overrun of 1 to 1.5 rotations. The braking current flows through the motor for approximately 0.4 seconds, after which the power supply to the motor is cut off automatically (The motor will have no holding torque).

### ● Long Life, Simple Wiring and Maintenance-Free

The electronic brake operates on current flow, so it lasts longer than the mechanically operated electromagnetic brake that is subject to wear. This makes the **SB50W** ideal for indexing applications. The electronic-input type brake pack doesn't use a power relay, so no maintenance is required. Wiring is easy as well.

### ● Link Electronic Brake and Electromagnetic Brake

By combining the **SB50W** with a motor equipped with an electromagnetic brake, you can link the electronic brake with the electromagnetic brake to allow the load to be held automatically following an instantaneous stop. This configuration is ideal for vertical applications in which the load must be held following the instantaneous stop of the motor.

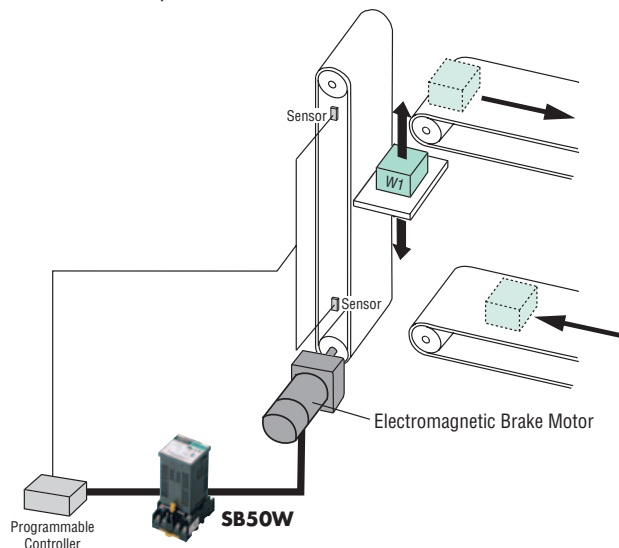

## Characteristics of the Brake Pack

### How to Read Braking Characteristics (Reference values)

The brake pack provides stable braking characteristics for the instantaneous stop of the motor. The braking characteristics are illustrated by the braking curve, which indicates the amount of overrun corresponding to the load inertia.

The braking time is  $4n/f$  seconds or less.

Where,  $n$ : overrun,  $f$ : power supply frequency.

For example, if the **4IK25GN-AW2U** [single-phase 115 VAC, 25 W (1/30 HP)] and **SB50W** are used together to stop a load with an inertia of  $J = 0.25 \times 10^{-4} \text{ kg}\cdot\text{m}^2$  (1.37 oz-in<sup>2</sup>), the overrun and braking time required will be approximately 1.4 rotations and 0.1 seconds, respectively, at a power supply frequency of 60 Hz. In the case of deceleration using a gearhead, refer to the braking characteristics curve after converting the load inertia at the gearhead shaft to its corresponding value at the motor shaft.

Use the following formula to convert the load inertia at the gearhead shaft to its corresponding value at the motor shaft:

$$J_M = \frac{J_G}{i^2} [\text{kg}\cdot\text{m}^2]$$

$J_M$ : Load inertia converted to corresponding value at the motor shaft

$J_G$ : Load inertia at the gearhead shaft

$i$ : Gear ratio of gearhead

### Stopping Accuracy

The figure to the right shows the stopping position error (variation in stopping position) when braking force is applied to the motor using the brake pack. The diagram shows an overrun distribution when braking is repeated 500 times under the same conditions. Varying stopping positions are caused by the power-supply phase when the switch is operated to apply the brake, which could generate a maximum delay of one cycle (power supply frequency) and variation in initial braking force. The sagging at the center reflects the slot-position relationship between the stator and rotor.

Refer to the braking characteristics curve representing the average overrun.

### Example of Braking Characteristics with Brake Pack

Brake Pack: **SB50W**

Motor: **4IK25GN-AW2U**

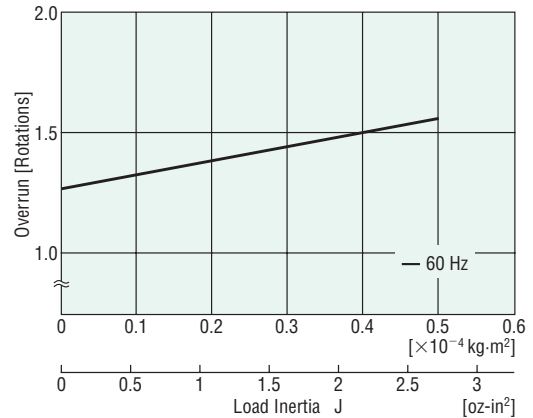

Brake Pack: **SB50W**

Motor: **4IK25GN-AW2U**

$J: 0.25 \times 10^{-4} \text{ kg}\cdot\text{m}^2$  (1.37 oz-in<sup>2</sup>)

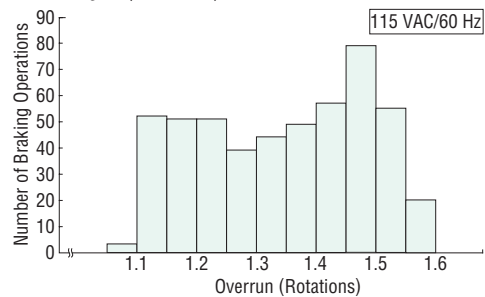

## Other Motor Braking Options

In addition to the brake pack, various other brake options are available to suit a variety of applications.

### How to Select a Brake Motor

#### Selecting Based on Stopping Accuracy

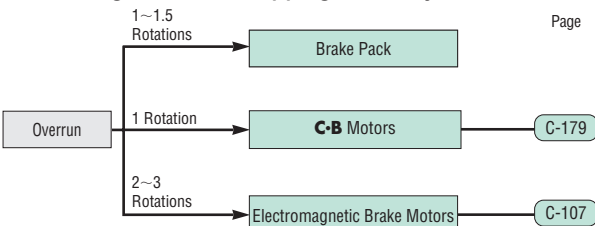

● The values for overrun applies to the motor only.

● For low-speed synchronous motors, the motor can be stopped instantly within  $\pm 10^\circ$  of stopping accuracy by turning off the power supply. Refer to page C-191 for details.

#### Selecting Based on Frequency of Use

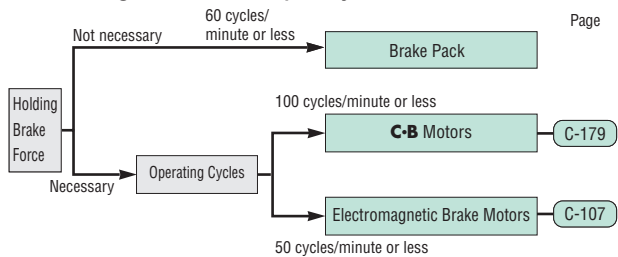

#### Notes

● The operating cycles are based merely on brake response. The value specified above is the maximum, so it may not be possible to repeat braking operation at this frequency.

● In an actual application, be certain the surface temperature of the motor case remains at  $90^\circ\text{C}$  ( $194^\circ\text{F}$ ) or less.

● For low-speed synchronous motors, if operated within the permissible load inertia, the motor can start, stop and reverse within 1.5 cycles of power supply frequency. Refer to page C-191 for details.

System Configuration

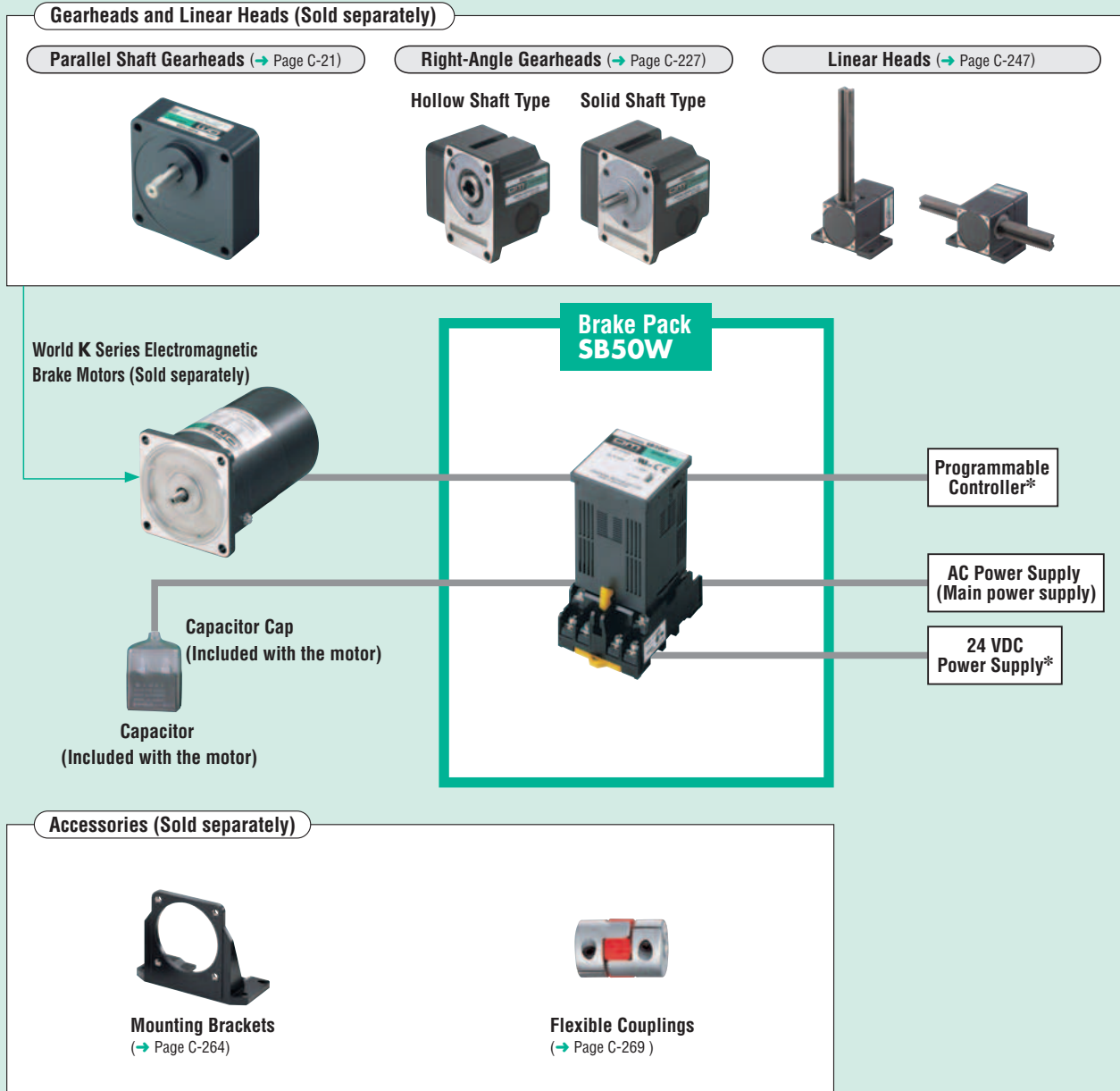

● Example of System Configuration

Brake Pack	Sold Separately		+	Sold Separately	
	Electromagnetic Brake Motor (Pinion shaft)	Long Life, Low Noise Gearhead		Mounting Bracket	Flexible Coupling
<b>SB50W</b>	<b>4RK25GN-AW2MU</b>	<b>4GN25SA</b>		<b>SOL4U10</b>	<b>MCL30F06F06</b>

● The system configuration shown above is an example. Other combinations are available.

\* Not supplied

## Product Line

Model	<b>SB50W</b>
-------	--------------

The following items are included in each product.  
 Brake Pack, Flush Mounting Socket, Operating Manual

## Specifications RoHS



Model	Power Supply Voltage	Frequency	Applicable Motor Output Power	Functions	Power Source for Control	Input Signals	Output Signals	Braking Current Duration
<b>SB50W</b>	Single-Phase 100-230 VAC ±10%	50/60 Hz	1 W~90 W (1/750 HP~1/8 HP)	Instantaneous stop Bi-directional operation Electromagnetic brake control (Only for electromagnetic brake motors) Thermal protector open detection (Alarm output) Sink/Source logic switch	24 VDC ±10% 0.1 A min.	CW, CCW, FREE/ALARM-RESET  Input specifications Photocoupler input Input resistance 4.7 kΩ 24 VDC ±10%	ALARM  Output specifications Open-collector output External use conditions 26.4 VDC max. 10 mA max.	Approximately 0.2~0.4 seconds

## General Specifications

Item	Specifications
Insulation Resistance	100 MΩ or more when 500 VDC megger is applied between the power supply input terminal and the signal input terminal after rated operation under normal ambient temperature and humidity.
Dielectric Strength	Sufficient to withstand 3.0 kVAC at 50 Hz or 60 Hz applied between the power supply input terminal and the signal input terminal for 1 minute after rated operation under normal ambient temperature and humidity.
Ambient Temperature	0~+40°C (+32~+104°F) (non-freezing)
Ambient Humidity	85% or less (non-condensing)
Degree of Protection	IP10

## Applicable Products

<b>World K Series</b> 1 W~90 W (1/750 HP~1/8 HP)	Induction Motors* Reversible Motors Electromagnetic Brake Motors
<b>V Series</b> 6 W~90 W (1/125 HP~1/8 HP)	Induction Motors Reversible Motors Electromagnetic Brake Motors
<b>FPW Series</b> 25 W~90 W (1/30 HP~1/8 HP)	Induction Motors

\* Except for 2-pole type

### Note

- Three-phase motors cannot be used in combination.

## Braking Current

When a motor is stopped instantaneously, a large half-wave rectified current flows through the motor for approximately 0.2 to 0.4 seconds. When connecting a circuit breaker, fuse or transformer, refer to the table below for the braking current (peak value) and select its current capacity.

Motor Output Power	Braking Current [A] (Peak Value)	
	110/115 VAC	220/230 VAC
1 W (1/750 HP)	1.0	—
6 W (1/125 HP)	1.5	1.0
15 W (1/50 HP)	4.5	2.5
25 W (1/30 HP)	7.5	4.0
40 W (1/19 HP)	12	7.0
60 W (1/12 HP)	18	8.5
90 W (1/8 HP)	26	17

## Dimensions Unit = mm (in.)

### ◇ SB50W

Mass: 0.1 kg (0.22 lb.)

DXF A092

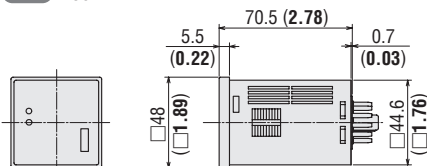

### ◇ Flush Mounting Socket (Included)

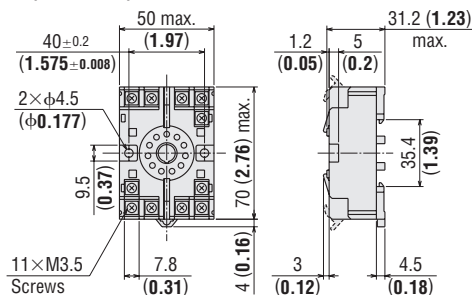

### ◇ Flush Mounting Socket Panel Cut-Out

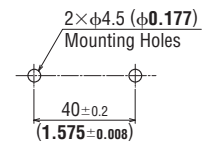

**Braking Characteristics (Reference values)**

● World K Series, V Series

◇ Induction Motors

1 W (1/750 HP)

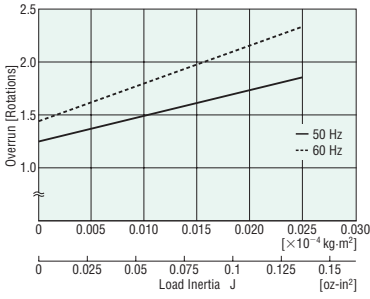

6 W (1/125 HP)

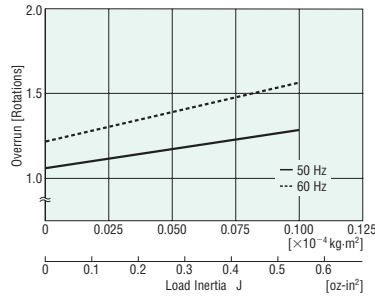

15 W (1/50 HP)

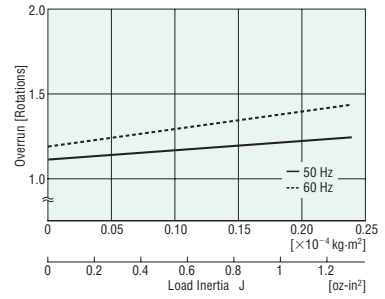

25 W (1/30 HP)

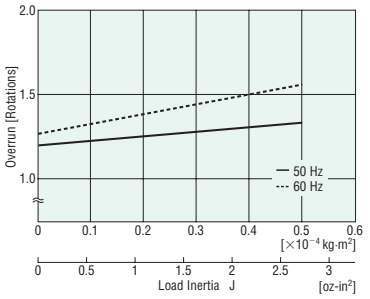

40 W (1/19 HP)

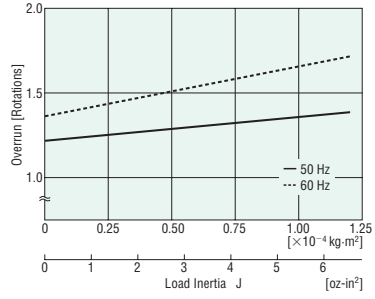

60 W (1/12 HP)

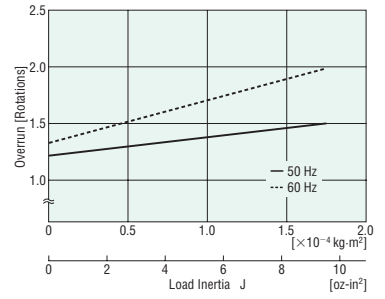

90 W (1/8 HP)

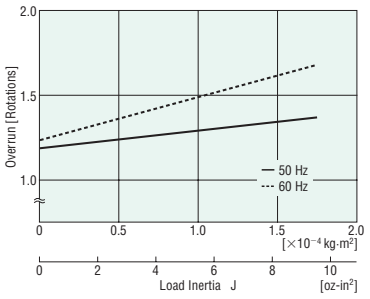

◇ Reversible Motors

1 W (1/750 HP)

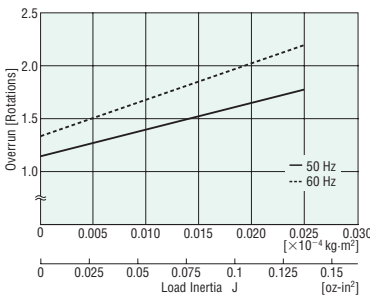

6 W (1/125 HP)

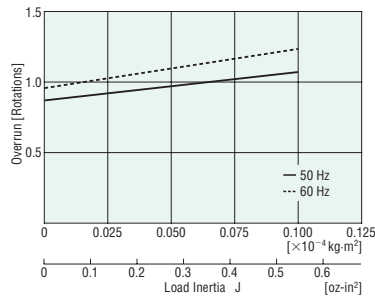

15 W (1/50 HP)

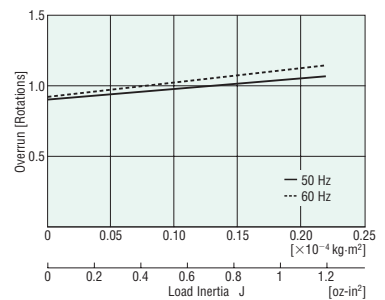

25 W (1/30 HP)

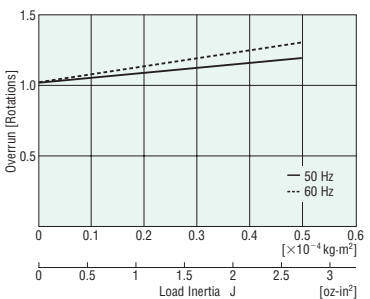

40 W (1/19 HP)

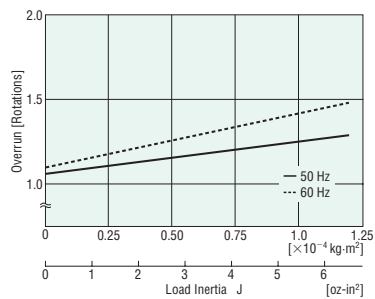

60 W (1/12 HP)

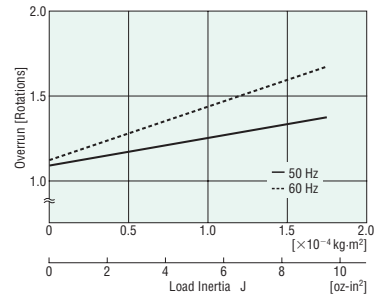

90 W (1/8 HP)

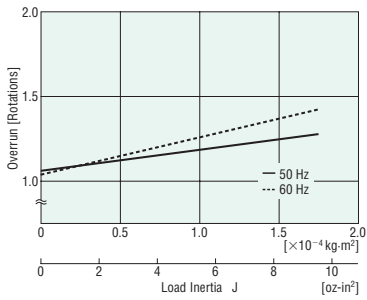

◇ Electromagnetic Brake Motors

6 W (1/125 HP)

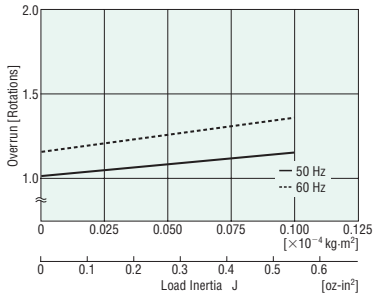

15 W (1/50 HP)

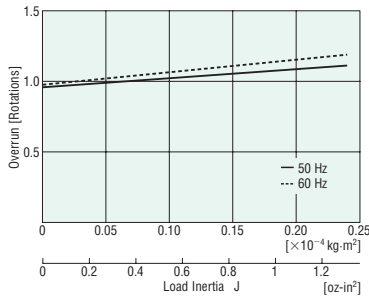

25 W (1/30 HP)

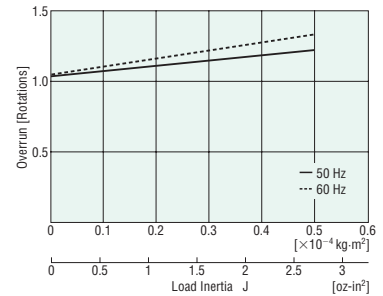

40 W (1/19 HP)

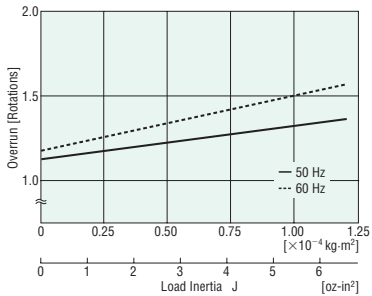

60 W (1/12 HP)

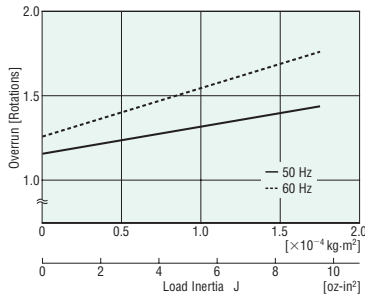

90 W (1/8 HP)

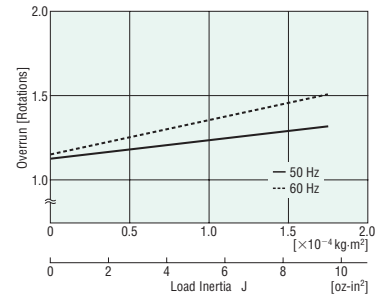

● FPW Series

25 W (1/30 HP)

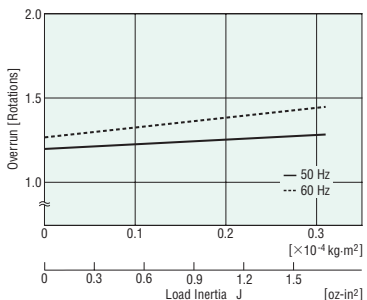

40 W (1/19 HP)

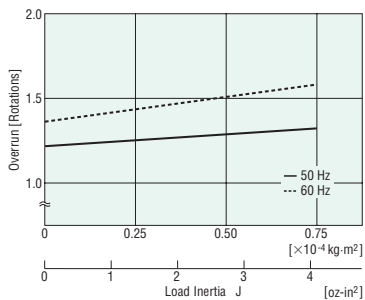

60 W (1/12 HP)

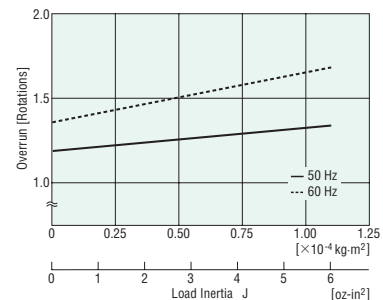

90 W (1/8 HP)

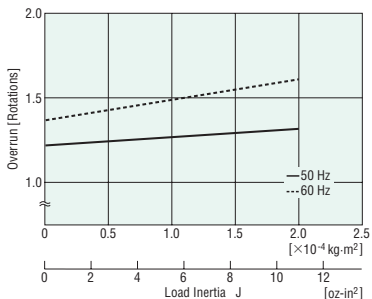

Introduction

Induction Motors

Reversible Motors

Electromagnetic Brake Motors

V Series

Clutch & Brake Motors

Synchronous Motors

Low-Speed Synchronous Motors

Waterright Dust-Resistant Motors

Torque Motors

Right-Angle Gearheads

Linear Heads

Brake Pack

Accessories

Installation

## Connection and Operation

### Names and Functions of Brake Pack Parts

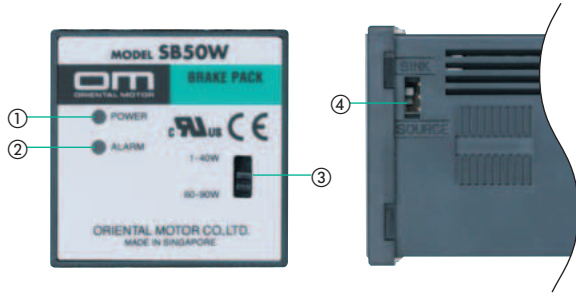

No.	Name	Factory Setting	Functions
①	POWER Indicator (Green)	—	Lights when 24 VDC is supplied.
②	ALARM Indicator (Red)	—	Lights when the ALARM is activated. (The ALARM output is "OFF.")
③	Motor Output Select Switch	60–90 W (1/12–1/8 HP)	Set to the motor output.
④	SINK/SOURCE Select Switch	SINK	Used to switch between Sink/Source for the control signal input/output.

### Connection Diagrams

The wiring diagram is for when the SINK/SOURCE select switch is set to "SINK."

#### World K Series, V Series

##### Induction Motors/Reversible Motors

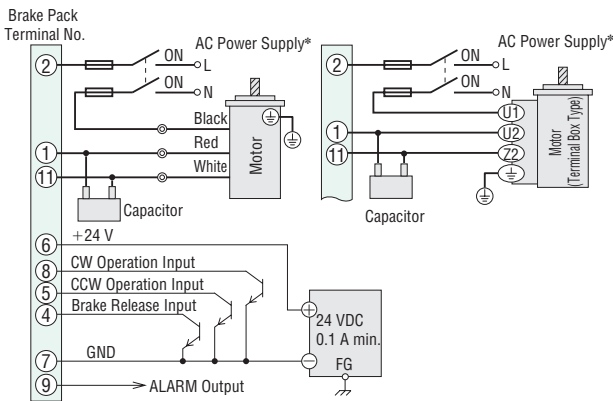

\* Single-phase 110/115 VAC, single-phase 220/230 VAC

#### FPW Series

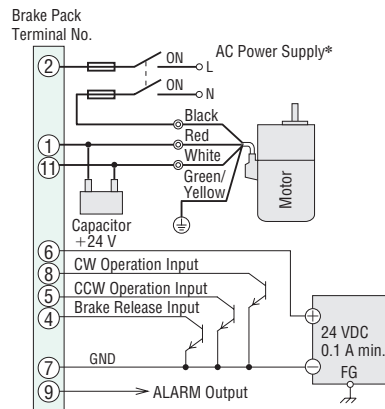

\* Single-phase 110/115 VAC, single-phase 220/230 VAC

##### Electromagnetic Brake Motors

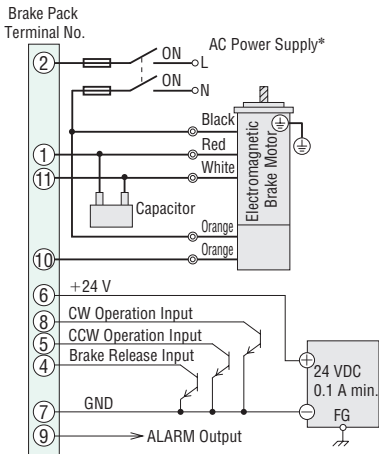

\* Single-phase 110/115 VAC, single-phase 220/230 VAC

### Terminal Arrangement for Flush Mounting Socket

Terminal No.	Signal Name	Description
①	Motor/Capacitor	Connect the motor and capacitor.
②	AC Power Supply Input (L)	Single-phase 100-115 VAC or Single-phase 200-230 VAC
③	NC	Not used. Leave this terminal unconnected.
④*1	Brake Release Input*2 ALARM-RESET Input	Not an instantaneous stop but coast to a stop. Reset ALARM Output.
⑤	CCW Operation Input	Motor rotates in the CCW direction during "ON."
⑥	DC Power Supply Input	+24 VDC input
⑦	GND	GND
⑧	CW Operation Input	Motor rotates in the CW direction during "ON."
⑨	ALARM Output	Turns OFF when the motor's thermal protector is open.
⑩	Electromagnetic Brake*3	Connect to the electromagnetic brake.
⑪	Motor/Capacitor	Connect to the motor and capacitor.

\*1 Functions as a brake release input during normal operation and as an ALARM-RESET input when the ALARM is activated.

\*2 Releases the electromagnetic brake for electromagnetic brake motors.

\*3 Only for electromagnetic brake motors

#### Notes

- The input signal voltage is 24 VDC ± 10%, 0.1 A min.
- Minimize the length of the motor cable and the input/output signal cable.
- Use a cable of AWG18 or more in diameter for the motor cable and power supply cable.
- Be sure to connect the GND terminal to GND (negative side) of the external control device or the motor will not operate.



## ● Input/Output Signal Circuit

The factory setting is sink logic for both input and output circuits. Select sink logic or source logic according to the external control device you will be using.

### ◇ Sink Logic

#### ● Input Circuit

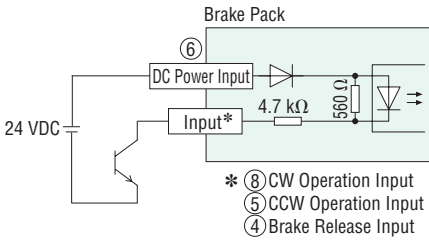

#### ● Output Circuit

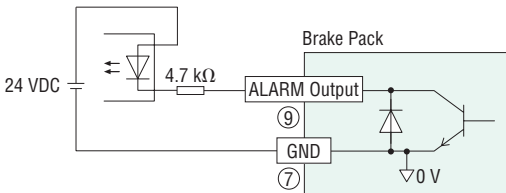

### ◇ Source Logic

#### ● Input Circuit

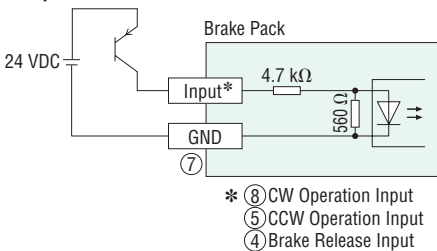

#### ● Output Circuit

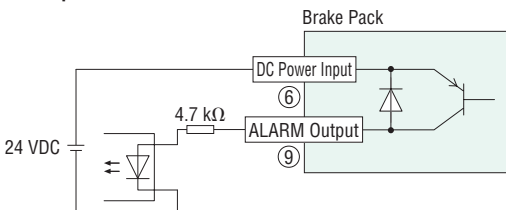

## ● Timing Chart

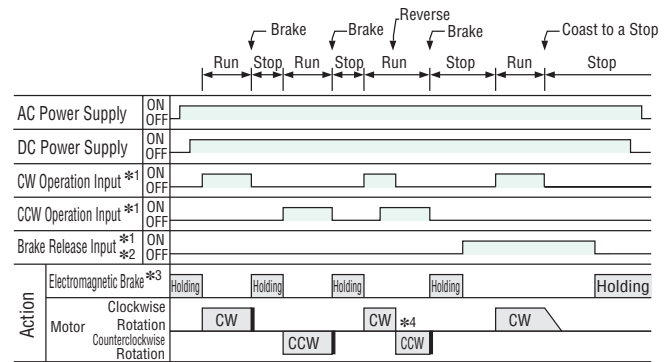

\*1 Turn on CW operation input, CCW operation input and brake release input after turning on AC power.

The motor will not operate if they are turned ON before the AC power is applied.

The ALARM indicator will light and ALARM output will switch to "OFF."

\*2 The brake release input becomes ALARM-RESET input when the ALARM output is OFF.

\*3 Only for electromagnetic brake motors.

\*4 The induction motor will not accommodate instantaneous bi-directional switching.

### ◇ CW Operation Input

Turning the CW operation signal to "ON" causes the motor's output shaft to turn in the CW direction. Turning it to "OFF" triggers an instantaneous stop.

### ◇ CCW Operation Input

Turning the CCW operation signal to "ON" causes the motor's output shaft to turn in the CCW direction. Turning it to "OFF" triggers an instantaneous stop.

If both the CW and CCW operation signals are simultaneously turned "ON," the CW operation signal will take priority.

### ◇ Brake Release Input [ALARM-RESET Input]

Functions as a brake release input during normal operation and as an ALARM-RESET input when the ALARM is activated.

#### ● When Normal Operation: Brake Release Input

Turning the brake release signal to "ON" disables both the electronic brake and electromagnetic brake. When the CW and CCW operation signals are turned "OFF," the motor operates by inertial force before coasting to a stop. When the motor is stationary, the electromagnetic brake is not activated, so the motor's output shaft can be moved freely.

Turning the brake release signal to "OFF" (or leaving the signal unconnected) and turning both CW and CCW operation signals to "OFF" will activate the electronic brake and electromagnetic brake, bringing the motor to an instantaneous stop. Once the motor stops, the electronic brake will be cut off automatically. However, the electromagnetic brake will continue to operate and hold the load.

• When an Alarm is Activated (When the ALARM output turns "OFF"): ALARM-RESET Input

When an alarm is activated, the ALARM output will turn "OFF." In this case, turn all input signals "OFF," and then input the ALARM-RESET signal for at least 0.5 seconds.

Wait at least 0.5 seconds after turning the ALARM-RESET input OFF before restarting operation.

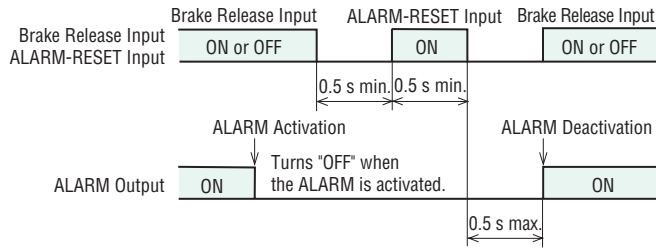

It is also possible to deactivate the alarm by turning off the power supply and turning it on again. Turn off the DC or AC power supply, and turn all input signals "OFF" before turning it on again.

◇ ALARM Output (Thermal Protector Open Detection)

Since the **SB50W** ALARM output function detects the action of the thermal protector, the current flowing in the motor is monitored. ALARM output is activated under the following conditions:

- When the motor's built-in thermal protector is activated (OPEN)
- When there is improper connection/disconnection of the power supply cable and motor cable
- When an input signal is turned "ON" before the AC power supply is turned on
- When the AC power supply is turned off while the motor is in operation or while it is stopped

In the above conditions, the **SB50W** ALARM function is activated and ALARM output is "OFF." Also, the ALARM indicator lamp (red) on the panel lights up, and power to the motor is cut off.

With electromagnetic brake motors, the brake is activated in order to hold the load in position.

**Note**

- When the DC power supply is turned on, the alarm indicator lamp (red) lights up briefly, but this is normal.

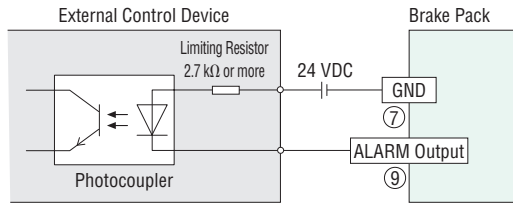

Use a power supply of 26.4 VDC max., and limit the output current to 10 mA max.

## Operating/Braking Repetition Cycle

Repeated operating and braking of a motor will cause a temperature rise in the motor and brake pack, thereby limiting the continuous operating time.

Observe the repetition cycle given in the table below for the operation and braking of the motor. The motor may generate heat depending on the conditions in which it is driven. Ensure that the temperature of the motor case does not exceed 90°C (194°F).

Motor Output Power	Repetition Cycle
1~25 W (1/750~1/30 HP)	2 seconds min.
40~90 W (1/19~1/8 HP)	4 seconds min.

(A repetition cycle of two seconds represents operation for one second and stopping for one second.)